

## PERFORMANCE IMPROVEMENT OF SOLID STATE TRANSFORMER

Patel Twinkalben Manilal<sup>\*1</sup>, Dr. Sanjay Jain<sup>2</sup>

<sup>\*1</sup>M.Tech Student, Department of Electrical Engineering, R.K.D.F. University, Bhopal, M.P.

<sup>2</sup>HOD, Department of Electrical Engineering, R.K.D.F. University, Bhopal, M.P.

<sup>1</sup>[twinkalpatel4532@gmail.com](mailto:twinkalpatel4532@gmail.com), <sup>2</sup>[jain.san12@gmail.com](mailto:jain.san12@gmail.com)

---

\* Corresponding Author: Patel Twinkalben Manilal

---

### Abstract

A high-frequency power electronic converter which has been used for the distribution of power transformer is known as solid-state transformer (SST). An SST with three-stage configuration commonly comprised of dc-ac inverter as well as isolated dc-dc dual-active-bridge (DAB) converter along with ac-dc rectifier. While driving a regulated single-phase dc-ac inverter, issue regarding the controller design has been addressed in this study for a dc-dc DAB converter. Whereas the inverter stage switching frequency is high as compared to the DAB stage, as a double-line-frequency the single phase inverter is model current sink (e.g., 100 Hz). The single-phase inverter with the effect of 100Hz current has been studied. at 100 Hz low gain with PID-controller has been investigated with limitation. For the improvement of the regulation of DAB converter output voltage, some approaches were anticipated for the usage of controller with an additional proportional-integral-derivative in the loop of feedback.

**Keywords:** DC-DC power converters, pulse width modulation converters, power smoothing.

---

### 1.1 INTRODUCTION

The Smart Grid is the emerging paradigm in energy generation and distribution, underpinning a concerted worldwide effort to improve and modernize electricity supply networks. A major feature of this new electrical network is the move to supply our energy demands with clean, renewable energy sources such as solar panels and wind turbines, rather than fossil fuel based generation systems [1]. In electrical terms, this represents a fundamental change in energy generation, moving away from non-volatile sources (e.g. fossil fuel fired power stations) towards volatile, non-schedulable sources (e.g. solar panels, whose output can be extremely variable). To sustain the grid in the face of these fluctuations in energy generation, the Smart Grid must include non-volatile energy storage as part of its core structure, to provide grid support and 'ride-through' capability during times of reduced primary energy production.

### 1.2 SOLID STATE TRANSFORMER

The main role of SSTs is that they acts as buffers among power grid, loads, distributed energy sources, and energy storage devices. By decoupling the load from the source, the consumers would not see the disturbance at the grid side because the disturbance is compensated by the SSTs. This is the advantage of SSTs for consumers. At the same time, the power grid would not see the reactive power generated by loads, which is compensated by SSTs. Therefore, the distribution system becomes more efficient and stable. This is the advantage of SSTs for the power grid. Additionally, SSTs are buffers for renewable power sources, which help reduce the impact of unpredictable and un-schedulable fluctuations of renewable electric power sources on both power grids and loads.

### 2.1 A GENERIC STRUCTURE FOR ISOLATED BI- DIRECTIONAL DC-DC CONVERTER

Almost all isolated bi-directional DC-DC converters reported in the literature follow the generic structure displayed in Fig. 1, and are essentially made up of two switching converters connected via an intermediate AC link that includes an isolation/scaling transformer.

The primary side converter converts the incoming DC voltage to an AC waveform, that has been applied to the intermediate transformer. The secondary converter then rectifies and filters this AC signal, creating a DC voltage that can be applied to a load. The symmetry of this structure allows the primary as well as secondary converters to swap roles without issue, allowing bi-directional power flow through the converter.

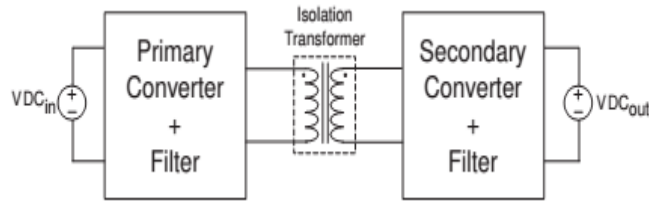

**Fig. 1:** The Generic Bi-directional DC-DC Converter Topology

### 2.2 FLYBACK CONVERTERS

The operation of this converter is explained. When switch S1 has been turned ON, current flows through the primary side of the converter, charging the magnetizing impedance of the isolating transformer. When S1 has been turned OFF, the current freewheels through the secondary winding of the transformer, supplying the load.

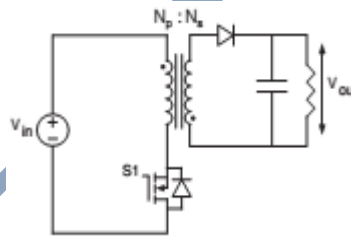

**Fig. 2:** A simple Fly back Converter

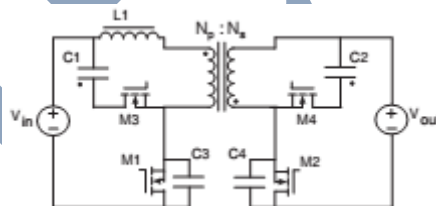

**Fig. 3:** The Actively Clamped Bi-directional Fly back Converter

### 2.3 CURRENT FED PUSH-PULL CONVERTERS

The operation of this converter is illustrated in Fig. 4. During the overlap period both switches S1 as well as S2 have been turned on, so the current builds up in the inductor L1. When only switch S1 is on, a net positive voltage appears on the transformer secondary ( $V \text{ sec}$ ). Conversely, a net negative voltage appears when only S2 is on. The resulting AC waveform is rectified to generate an isolated DC output voltage.

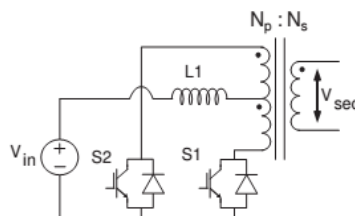

**Fig. 4:** A Current fed push-pull converter

### 3.1 MODULATION

In this section, the modulation strategies that have been applied in the literature to full-bridge isolated bi-directional DC-DC converters are presented and their key features described. The two key modulation strategies that have been applied to these converters are Pulse Width Modulation (PWM) & block modulation. This section describes both these strategies in terms of the H-bridge converter of Fig. 5, then evaluates their benefits and drawbacks.

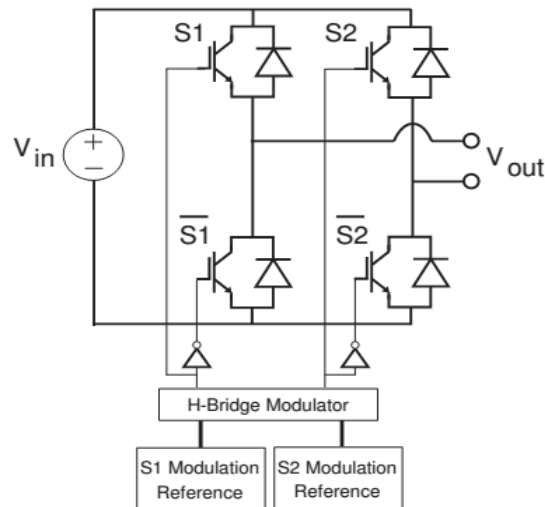

**Fig. 5:** H-bridge and Modulator

### 3.2 PULSE WIDTH MODULATION

PWM is one of the most popular bridge converter modulation schemes. Many different types of PWM schemes have been proposed in modulation literature, ranging from Naturally Sampled & Regular Sampled PWM through to Discontinuous Modulation schemes, to Space Vector modulation strategies. All these modulation strategies share a common operating principle, i.e. a high frequency switching pulse train whose widths vary more slowly to give a Low Frequency average (fundamental) output AC waveform.

### 4.1 DYNAMIC MODELLING

Having reviewed the different topologies that have been applied to isolated bidirectional DC-DC converters as well as their modulation techniques, this literature review now shifts focus to the dynamic modeling and control of these converters.

An accurate dynamic model is essential for the design of a high performance closed loop controller. Without such a model, regulator design is essentially a heuristic process and maximized performance is not guaranteed.

### 4.2 LINEAR CONTROL

Linear controllers are the most popular type of closed loop strategy proposed in the literature to regulate isolated bi-directional DC-DC converters. A large number of linear controllers exist in the literature (Proportional + Integral controllers, pole placement controllers, etc.). This section outlines their key design features and evaluates their performance.

This review is simplified by the fact that all linear controller designs essentially follow the same sequential process, i.e.:

1. Regulator target variable selection
2. Loop design

### 3. Regulator design

The step-by-step nature of this process is utilized in this review by presenting each alternative controller solution in the context of this process.

## 5. RESULTS

The multistage ac–dc–ac–dc–ac configuration is implemented driving single-phase inverter. In this model a dc bus is taken as a constant voltage source where interface between a medium-voltage distribution network 4.2 kV and a low-voltage distribution network 230 V. The output voltage and the output current of the inverter stage are grid frequency, while the input and output voltages of the dual-active-bridge (DAB stag) converter are dc. In this model line frequency is assumed to be 50 Hz , so the ripple current in the output capacitor is at 100 Hz.

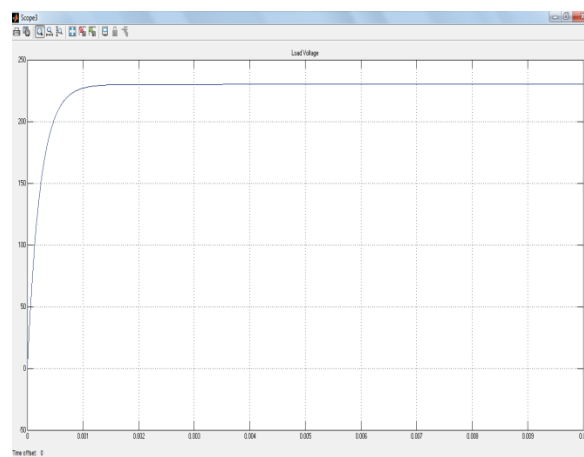

**Fig. 6:** Simulation Waveform of Output Voltage of DAB Converter

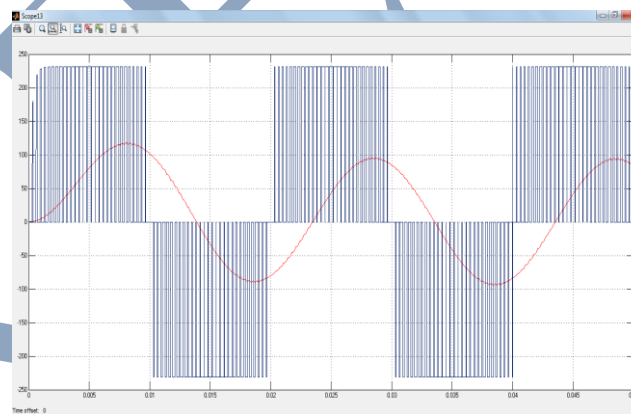

**Fig. 7:** Simulation Waveform of Output Voltage and Current

## 6. CONCLUSION AND FUTURE SCOPE

The multistage configuration of an SST, a dc–dc DAB converter drives a single-phase dc–ac inverter. The cascaded connection of power converters poses a challenge for the closed loop controller design. A single-phase inverter has significant second-order harmonic current in its input side. A conventional PI controller has limited bandwidth at 100 Hz because of the relatively low switching frequency of the DAB converter. Simply increasing switching frequency would not result in higher bandwidth. In future more robust and simple fuzzy technique also can be developed for second harmonics problem. To achieve more accurate a nonlinear controller Fuzzy controllers can be designed based on the general knowledge of the converters.

## REFERENCES

- [1] S. Bhattacharya, T. Zhao, G. Wang, S. Dutta, S. Back, Y. Du, B. Parkhideh, X. Zhou, and A. Q. Huang, "Design and development of Generation-I silicon based solid state transformer," in IEEE Applied Power Electronics Conference and Exposition (APEC), 2010, pp. 1666–1673, 2010.
- [2] U.S. Department of Energy, "The smart grid: An introduction." <http://energy.gov/oe/downloads/smart-grid-introduction>, 2010.
- [3] M. D. Manjrekar, R. Kieferndorf, and G. Venkataramanan, "Power electronic transformers for utility applications," in IEEE Industry Applications Society (IAS) Annual Meeting, 2000, vol. 4, pp. 2496–2502, 2000.
- [4] U.S. Department of Energy, "The smart grid: An introduction." <http://energy.gov/oe/downloads/smart-grid-introduction>, 2010.
- [5] M. Khazraei, H. Sepahvand, K. Corzine, and M. Ferdowsi, "Active capacitor voltage balancing in single-phase flying-capacitor multilevel power converters," IEEE Transactions on Industrial Electronics, vol. 59, pp. 769–778, Feb. 2012.
- [6] R. De Doncker, D. Divan, and M. Kheraluwala, "A three-phase soft-switched high-power-density dc/dc converter for high-power applications," IEEE Transactions on Industry Application, vol. 27, pp. 63–73, Jan./Feb. 1991.
- [7] M. N. Kheraluwala, R. W. Gascoigne, D. M. Divan, and E. D. Baumann, "Performance characterization of a high-power dual active bridge," IEEE Transactions on Industry Application, vol. 28, pp. 1294–1301, Jun. 1992.
- [8] F. Peng, H. Li, G.-J. Su, and J. Lawler, "A new ZVS bidirectional dc-dc converter for fuel cell and battery application," IEEE Transactions on Power Electronics, vol. 19, pp. 54–65, Jan. 2004.
- [9] H. Bai and C. Mi, "Eliminate reactive power and increase system efficiency of isolated bidirectional dual-active-bridge dc-dc converters using novel dual-phase-shift control," IEEE Transactions on Power Electronics, vol. 23, pp. 2905–2914, Nov. 2008.
- [10] Z. Haihua and A. M. Khambadkone, "Hybrid modulation for dual-active-bridge bidirectional converter with extended power range for ultracapacitor application," IEEE Transactions on Industry Application, vol. 45, pp. 1434–1442, Apr. 2009.
- [11] J. Kim, I. Jeong, and K. Nam, "Asymmetric duty control of the dual-active bridge dc/dc converter for single-phase distributed generators," in IEEE Energy Conversion Congress and Exposition (ECCE), 2009, pp. 75–82, Sept. 2009.
- [12] H. Plesko, J. Biela, and J. Kolar, "Novel modulation concepts for a drive integrated auxiliary dc-dc converter for hybrid vehicles," in IEEE Applied Power Electronics Conference and Exposition (APEC), 2009, pp. 164–170, Feb. 2009.

RESERVIEW