

ELECTRICITY GENERATION THROUGH SOLAR AND WIND BASED HYBRID ENERGY SYSTEM – A REVIEW

Ashish Ranjan¹, Dr. Saroj Kumar Dash²

¹Department of Electrical Engineering, Gita Autonomous College, Bhubaneswar Odisha, India

²Department of Electrical Engineering, Gita Autonomous College, Bhubaneswar Odisha, India

¹ashishguptar2345@gmail.com, ²hodeegita@gmail.com

* Corresponding Author: Ashish Ranjan

Abstract: Electricity is a necessary resource for human living, just like oxygen and water are. Fossil fuels, which are scarce, are the main ingredient in the production of energy. Fossil fuel-based power plants also emit the atmospheric pollutants CO₂, SO_x, and NO_x. The electrical power system's dependence on fossil fuels has decreased, environmental pollution has been minimized, the reliability of the electric network has improved, and renewable energy systems are now regarded a green energy source. The function of hybrid energy systems based on solar and wind is examined in this research. In the literature review, we also covered several small power system types and research projects related to the use of solar and wind hybrid systems for the production of energy.

Keywords: Hybrid Energy System, Renewable Energy Systems, Small Power Systems, etc.

I. Introduction

A hybrid energy system combines different energy generating and/or storage methods, or it uses a generator that is powered by two or more different forms of fuel. A hybrid energy system is an effective strategy for moving away from economies that rely on fossil fuels. It can really help increase the usage of renewable energy sources to support renewable generating with traditional thermal power production, especially in the short term while new technologies to better integrate renewable energy sources are still being developed.

Any nation's ability to industrialize, urbanize, and prosper economically depends on electricity [1]. Electricity is produced using a variety of traditional and unconventional energy sources. One of the most well-known energy sources is the solar and wind energy systems. Due to its modularity and eco-friendliness, solar and wind energy systems are being used more and more. The utilization of standalone to utility interactive solar-wind systems has grown significantly over the past 20 years in the field of solar-wind energy. Although solar and wind energy systems function normally in standalone and grid-connected modes, their efficiency is lower due to the stochastic nature of these resources. This weakness of being unpredictable in nature is overcome by hybrid alternative energy sources with grid integration.

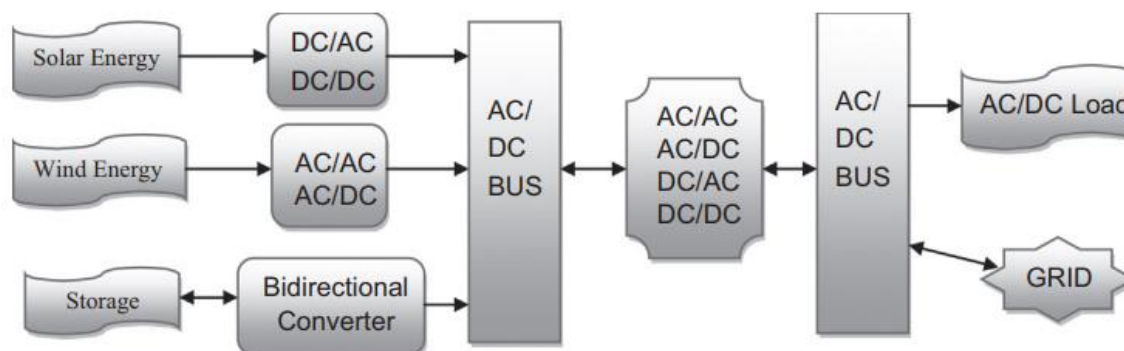

Figure 1 Basic component of solar-wind hybrid renewable energy system

Over the past ten years, numerous hybrid solar systems have been built in numerous nations, leading to the creation of systems that can compete with traditional, fuel-based remote area power supply [2] in a variety of applications. Research has concentrated on the construction of effective power converters, such as bi-directional inverters and battery management units, and the evaluation metrics [2] of demonstration systems. Power point trackers at their maximum. There are numerous simulation tools that provide the best hybrid energy system sizing.

Due to the likelihood that conventional resources won't be as readily available in the future, renewable energy alternatives are being investigated. Dependence on geographic locations and climatic circumstances is the fundamental negative of renewable energy sources, but the main issues with these hybrid systems are their high initial cost, increasing maintenance costs, and various rates of depreciation [3]. The irregular distribution of natural resources requires the creation of a hybrid system that can provide the greatest amount of energy imaginable for uninterrupted and dependable operations [3]. Several aspects, including the state of the sites, the availability of energy, the efficiency of the energy sources, as well as physical and social constraints, have an impact on how hybrid systems are designed. Combining the best sizing techniques is essential in this case in order to get higher reliability quality at the lowest cost. Renewable

energy sources, nonrenewable generators, controls, storage systems, loads, and occasionally the grid are the basic components of hybrid energy systems.

The electric power grid's use of wind and solar energy has greatly increased over the past few years, and it is anticipated that this trend will continue to rise in the next years. Although the high degree of intermittency of wind and solar power has been adequately managed by electrical grid operators, the addition of more of these sources to the grid would present new challenges. In particular, variations brought on by wind and solar power may demand novel methods for operating and planning the electrical grid. A wide variety of tactics and strategies are used to overcome the complementarity issue [4]. Benefits of integrating wind and solar power generation can be connected, regardless of the geographic location or analytic method. When integrated into a large number of geographically separated places, the combined usage of wind and sun generated power is beneficial. The main issue is not how these sources vary or fluctuate, but rather how to appropriately address these features.

Table 1 Characteristics of Renewable Energy Power System

Benefits	Drawbacks
Use free resources like the sun and wind for fuel	Renewable energy production is dependent on natural cycles Initial
Operation and maintenance requirements are low	Initial cost of these systems are higher than comparably sized conventional generators
No problem of pollution or waste natural resources	Cannot handle the peak-loads well without energy storage

II. Types of Small Power System

Small power systems are mostly utilized to supply electricity to remote and rural locations. Mini-grid development has increased in tandem with lower costs for inverter, solar, and wind technologies. Small power systems can be broadly divided into grid-tied and off-grid power systems depending on how they are connected to the main grid. Each form of power system is depicted in detail in Fig. 6.

A. Off-Grid Systems (Stand-Alone System)

Off-grid power systems make up the majority of small power systems that are created and optimized to supply the energy needs of remote locations. A system that is off-grid is not connected to the main electrical grid. The size and use of standalone systems range greatly, from watches or calculators to distant buildings or spacecraft.

B. Grid Tied Systems

A grid-connected system sends energy directly into the grid by connecting to a larger, independent grid, generally the public electricity grid [2]. A synchronizing grid-tie inverter must convert DC into AC before electricity can be fed into the grid (also called grid-interactive inverter).

III. Hybrid Power Systems

In order to generate electricity, hybrid power systems can use a variety of power-generating technologies, including fossil-fuel-powered generators, solar panels, wind turbines, and micro hydropower. These systems can be modest enough to power a single house or large enough to power an entire community or an island. Many isolated villages, especially those in poor countries where the national grid is economically and technically unviable, are assumed to be powered by hybrid power systems.

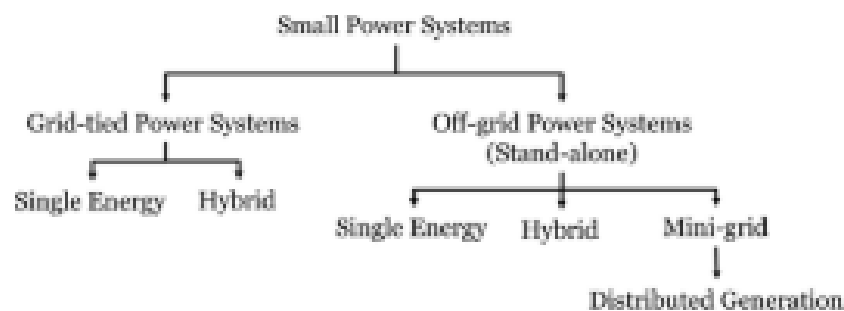

Figure 2 Classification of small power systems based on grid connection

IV. Literature Review

(Chandra et al., 2018) examines how different real-time MPPT control techniques have an impact on wind-solar hybrid renewable energy systems (HRES). This study will provide the general trends in MPPT schemes from previous research

surveys and examine the cutting-edge developments in intelligent strategies for wind-solar hybrid energy systems. The current state of the art and the effectiveness of novel intelligent control strategies will also be evaluated in terms of array reliance, wind speed, convergence time, handling shading circumstances, and practical application. This review work is intended to anticipate the use of cutting-edge artificial intelligence (AI) control algorithms as a guide for future innovations in effective hybrid energy system usage.

(Weschenfelder et al., 2020) One of the key components of extensive grid integration is the investigation of the utilization of wind and solar energy simultaneously. As a result, the objective of this work is to conduct a critical analysis of the most recent methods for comprehending and evaluating the complementarity between grid-connected solar and wind power systems through the analysis of various techniques and contexts. 41 publications were identified by the literature review and examined in the manuscript. A more reliable power supply is achieved by combining wind and solar energy in numerous locations, which is essential for the operation and security of electrical systems worldwide.

(Lian et al., 2019) examines the most modern methods for classifying, evaluating, and sizing hybrid renewable energy systems (stand-alone and grid-connected). For hybrid renewable energy systems to perform better overall, more optimization research is still needed. Depending on their supremacy, decision-makers can investigate and create hybrid systems that include hydropower and/or pumped hydro storage, but they should also focus on the advancement of hybrid energy storage. To evaluate the system capacity, consideration should be given to environmental and social indicators in addition to reliability and economic indicators, which have applications exceeding 80%. Additionally, some additional indicators should be made available. In addition to software tools, the characteristics of conventional, artificial intelligence, and hybrid methodologies were evaluated.

(Khan et al., 2018) put your attention on wind and solar photovoltaic (PV) hybrid energy solutions. The different economic feasibility metrics, sizing tactics with logical innovations to improve their utilization, future prospects, and their arrangement were all clarified in this research. Here are some tips on how to create a useful storage system. For hybrid renewable energy systems, a brief overview of recent developments in optimization approaches, reliability indices, and cost analysis tools is also provided.

(Nema et al., 2009) Continued research and development is necessary for enhancing the performance of solar, wind, and other renewable energy technologies, developing methods for precisely forecasting their output, and successfully integrating them with other traditional power sources. The purpose of this study is to assess the state of the art for stand-alone PV solar-wind hybrid energy systems with a traditional backup source, such as diesel or the grid. The future improvements that could improve the economic allure of such systems and the user's acceptance of them are also highlighted in this paper.

(Al Busaidi et al., 2016) examines the many hybrid PV-Wind renewable energy systems utilized to generate electricity. The best logistical, environmental, and financial factors for sizing the various system components of a hybrid renewable energy power plant have been examined. The research also explored a few optimization strategies that are used to compare the performance and cost of energy generation across various hybrid system configurations using simulation methodologies.

(Khare et al., 2016) An HRES (hybrid renewable energy system) combines renewable and alternative energy sources, such as a solar panel and wind turbine. The purpose of this essay is to provide an in-depth analysis of many HRES-related topics. Prefeasibility analysis, optimal sizing, modeling, control considerations, and reliability difficulties are covered in this study. This paper also discusses the use of evolutionary technique and game theory in hybrid renewable energy.

(Bajpai & Dash, 2012) The purpose of this work is to examine the research on the component hybrid renewable energy system unit sizing, optimization, energy management, and modeling. In-depth discussions have been held regarding new developments in modeling research for hybrid energy resources (PV systems), backup energy systems (Fuel Cell, Battery, Ultra-capacitor, Diesel Generator), power conditioning components (MPPT converters, Buck/Boost converters, Battery chargers), and methods for managing energy flow. An effort has been made in this study to offer a thorough evaluation of the research that has been done in this field over the previous ten years.

V. Conclusion

Like water and oxygen, electricity is an essential resource for maintaining human life. The primary component in the creation of energy is the rare fossil fuel. In addition to NO_x and SO_x, fossil fuel-based power plants also release CO₂ into the atmosphere. The reliance of the electrical power system on fossil fuels has been reduced, environmental pollution has been reduced, the electrical network's dependability has increased, and renewable energy systems are now considered green energy sources. In this study, the operation of hybrid solar-wind energy systems is investigated. Additionally, we discussed several types of compact power systems and research initiatives on the production of hybrid solar and wind energy.

References

- [1] S. Bahramara, M. P. Moghaddam, and M. R. Haghifam, "Optimal planning of hybrid renewable energy systems using HOMER: A review," *Renew. Sustain. Energy Rev.*, vol. 62, pp. 609–620, 2016, doi: 10.1016/j.rser.2016.05.039.
- [2] Y. S. Mohammed, M. W. Mustafa, and N. Bashir, "Hybrid renewable energy systems for off-grid electric power: Review of substantial issues," *Renew. Sustain. Energy Rev.*, vol. 35, pp. 527–539, 2014, doi: 10.1016/j.rser.2014.04.022.
- [3] P. Bajpai and V. Dash, "Hybrid renewable energy systems for power generation in stand-alone applications: A review," *Renew. Sustain. Energy Rev.*, vol. 16, no. 5, pp. 2926–2939, 2012, doi: 10.1016/j.rser.2012.02.009.
- [4] J. Jurasz, A. Beluco, and F. A. Canales, "The impact of complementarity on power supply reliability of small scale hybrid energy systems," *Energy*, vol. 161, pp. 737–743, 2018, doi: 10.1016/j.energy.2018.07.182.
- [5] Z. A. Khan, M. Imran, A. Altamimi, O. E. Diemuodeke, and A. O. Abdelatif, "Assessment of wind and solar hybrid energy for agricultural applications in Sudan," *Energies*, vol. 15, no. 1, 2022, doi: 10.3390/en15010005.
- [6] S. Upadhyay and M. P. Sharma, "A review on configurations, control and sizing methodologies of hybrid energy systems," *Renew. Sustain. Energy Rev.*, vol. 38, no. October, pp. 47–63, 2014, doi: 10.1016/j.rser.2014.05.057.
- [7] M. Ramesh, A. K. Yadav, and P. K. Pathak, "An extensive review on load frequency control of solar-wind based hybrid renewable energy systems," *Energy Sources, Part A Recover. Util. Environ. Eff.*, vol. 00, no. 00, pp. 1–25, 2021, doi: 10.1080/15567036.2021.1931564.
- [8] D. W. & Medugu, E. Michael, and D. W. Medugu, "Integrated Solar – Wind Hybrid Power Generating System for Residential Application," vol. 14, no. 4, 2014.
- [9] S. Chandra, P. Gaur, and Srishti, "Maximum power point tracking approaches for wind–solar hybrid renewable energy system—a review," *Lect. Notes Electr. Eng.*, vol. 508, pp. 3–12, 2018, doi: 10.1007/978-981-13-0662-4_1.
- [10] F. Weschenfelder et al., "A review on the complementarity between grid-connected solar and wind power systems," *J. Clean. Prod.*, vol. 257, p. 120617, 2020, doi: 10.1016/j.jclepro.2020.120617.
- [11] J. Lian, Y. Zhang, C. Ma, Y. Yang, and E. Chaima, "A review on recent sizing methodologies of hybrid renewable energy systems," *Energy Convers. Manag.*, vol. 199, no. September, p. 112027, 2019, doi: 10.1016/j.enconman.2019.112027.
- [12] F. A. Khan, N. Pal, and S. H. Saeed, "Review of solar photovoltaic and wind hybrid energy systems for sizing strategies optimization techniques and cost analysis methodologies," *Renew. Sustain. Energy Rev.*, vol. 92, no. December 2017, pp. 937–947, 2018, doi: 10.1016/j.rser.2018.04.107.
- [13] B. Bhandari, K. Lee, G. Lee, Y. Cho, and S. Ahn, "Optimization of Hybrid Renewable Energy Power Systems : A Review," vol. 2, no. 1, pp. 99–112, 2015.
- [14] V. Khare, S. Nema, and P. Baredar, "Solar-wind hybrid renewable energy system: A review," *Renew. Sustain. Energy Rev.*, vol. 58, pp. 23–33, 2016, doi: 10.1016/j.rser.2015.12.223.
- [15] P. Nema, R. K. Nema, and S. Rangnekar, "A current and future state of art development of hybrid energy system using wind and PV-solar: A review," *Renew. Sustain. Energy Rev.*, vol. 13, no. 8, pp. 2096–2103, 2009, doi: 10.1016/j.rser.2008.10.006.
- [16] A. S. Al Busaidi, H. A. Kazem, A. H. Al-Badi, and M. Farooq Khan, "A review of optimum sizing of hybrid PV-Wind renewable energy systems in oman," *Renew. Sustain. Energy Rev.*, vol. 53, pp. 185–193, 2016, doi: 10.1016/j.rser.2015.08.039.