

---

## Thermal Analysis of Triple Effect Vapour Absorption Refrigeration System

---

Madhav Kumar, Prof. Manish Singh Bharti  
M.Tech Scholar, Department of Mechanical Engineering, RNTU Bhopal  
Prof, Department of Mechanical Engineering, RNTU Bhopal

**Abstract:** The vapour compressor used in the vapour compression cycle is swapped out for an absorber and a generator in the absorption cycle. Additionally, in the vapour compression cycle, the input energy is given by the mechanical effort of both the compressor, but in the absorption cycle, the input energy is supplied by heat that is transferred directly to the generator. Typically, low-quality energy sources like waste heat, renewable energy, etc. are used to provide the generator with heat. Although novel mixes are being researched, the environmental friendliness and widespread usage of ammonia-water and LiBr-H<sub>2</sub>O for refrigeration in absorption systems indicate that the former has a brighter future.

**Keywords:** Triple Effect, Vapour Absorption, Refrigeration System

### 1. Introduction

Recent evaluations of refrigeration cycles with both greater and lower evaporator temperatures consider energy, exergy, economy, environment, and safety techniques. Freeze drying, pharmaceuticals, chemicals, and the petroleum sector all employ cascade refrigeration cycles [1] because of the extremely low temperatures required. Air conditioning units operate at roughly 0 degrees Celsius, whereas industrial refrigeration units operate at 35 to 50°C. High heat flux electronics, quick freezing, frozen food, and cold storage all have rising needs for refrigeration at low evaporation temperatures [2–5]. According to Tassou et al. [5], refrigerating food between 18 and 35°C helps slow down the physical, chemical, and microbiological processes that cause degradation in food. Mechanical refrigeration systems are almost always used in such procedures, despite their high-power use, negative environmental effect, and lacklustre performance.

Vapor absorption refrigeration, vapour compression refrigeration, and other similar methods all fall under this category. The vapour compression refrigeration cycle has the best performance, but it uses more power than the other options.

Since it can provide greater cooling capacity than vapour compression systems and run on non-electrical energy sources (such as waste heat from gas and steam turbines, the sun,

geothermal energy, and biomass), the absorption refrigeration system (ARS) is gaining in popularity. In addition, an ARS does not contribute to ozone depletion and is hence environmentally benign. Thermodynamic analysis and performance characteristics of ARSs have been the subject of both theoretical and experimental investigations. In the absorption cycle, the vapours of the refrigerant (ammonia) are transferred from the evaporator to the condenser via a concentration difference produced by the application of heat. A portion of the cycle with a high concentration of both the refrigerant absorbs the vapours (which, of course dilutes that material). The concentration of the refrigerant would then be raised while using heat to force out the vapours. Commercial refrigeration systems typically employ water as their absorbent and ammonia as their refrigerant. Sometimes water is used as the absorbent and ammonia as the refrigerant in smaller absorption chillers. Chilled ammonia is supplied through cooling the water used in the evaporator to the temperature required by the air handlers. It's really the hygroscopic properties of the concentrated water solution that allow it to absorb the ammonia vapour. At a greater pressure, the solution is transferred to the concentrator, where the ammonia is driven off by heat, and indeed the water is re-concentrated.

After the heat input stage, the ammonia that was released must be condensed, collected, and flashed to the necessary low temperature in order to complete the cycle. In this cycle, ammonia acts as the refrigerant because it transfers heat from the evaporator to the condenser. Absorption refrigeration systems has become increasingly popular in recent years because to its eco-friendly refrigerant and absorbent pair. In light of this, there is a concerted effort to make the most of our energy sources by cutting back on our use, and there is also research being done to find alternatives to the ozone-depleting refrigerants that are now in use. Using a volatile refrigerant, the absorption refrigeration cycle is analogous to the vapour compression cycle. In a typical refrigeration cycle, ammonia or water is used, first vaporising at low pressure in the evaporator by drawing latent heat from the substance to be cooled, and then condensing at high pressure in the condenser by giving up the latent heat to the condensing medium.

The vapour compressor used in the vapour compression cycle is swapped out for an absorber and a generator in the absorption cycle. Additionally, in the vapour compression cycle, the input energy is given by the mechanical effort of both the compressor, but in the absorption cycle, the input energy is supplied by heat that is transferred directly to the generator. Typically, low-quality energy sources like waste heat, renewable energy, etc. are used to provide the generator with heat. Although novel mixes are being researched, the

environmental friendliness and widespread usage of ammonia-water and LiBr-H<sub>2</sub>O for refrigeration in absorption systems indicate that the former has a brighter future [3]

## **2. Past studies**

**Agarwal et al. (2020)** developed a theoretical understanding of an ACCRS (absorption-compression cascade refrigeration system) for use in low-temperature cooling settings. In the upper temperature segment, a vapour absorption refrigeration (VAR) system using H<sub>2</sub>O - LiBr in a series flow is paired with a VCR system employing R1234yf as the refrigerant. Utilizing waste available from the exhaust of gas turbine or steam turbine to run the triple effect vapour absorption refrigeration system, the cascade system provides lower temperatures (i.e. 223.15- 263.15 K) for freeze drying, pharmaceuticals, chemicals, and the petroleum industry at lower running costs. Additionally, the usage of R1234yf prevents harmful greenhouse gas emissions and ozone depletion.

**Chen et al. (2020)** evaluated the energy and exergy efficiency of a proposed hybrid system that combines a phosphoric acid fuel cell (PAFC) and a triple-effect compression-absorption refrigerator using [mmim]DMP/CH<sub>3</sub>OH as the working fluid (HFCAR). Based on the existing density model of PAFC, the isentropic efficiency model of aided compressor, and the mass and energy conservation model of the compression- absorption refrigerator, the HFCAR system was designed and simulated. Assuming the initial design condition, the specific operational parameters.

**Dubey et al. (2020)** demonstrate a deep familiarity with both basic and advanced refrigeration processes. Furthermore, the present state of vapour absorption refrigeration cycles, with an emphasis on any enhanced performance, has been reviewed. Using an ejector, generator absorber heat exchanger, and booster compressor, several vapour absorption cycles have been theoretically examined. Compared to traditional vapour compression refrigeration, triple-effect systems, and GAX systems, a hybrid vapour compression-absorption refrigeration system offers a significantly higher COP.

**Waseem et al. (2020)** That used an electrolyzer for hydrogen production, a regenerative Rankine Cycle for work rate, and a vapour absorption cycle for cooling, this study compared and contrasted three different integrated multigenerational systems. That both pace at which hydrogen is created by the electrolyzer and the amount of electricity provided by the proposed systems were found to vary depending on where they were located in the system. Both systems, comprising all relevant components, are subjected to comprehensive energetic and exergetic studies. By altering a few settings, we can see how the system responds to these

modifications and how they affect our total efficiency.

**Azhar et al. (2020)** Double effect parallel flow direct and indirect fired vapour absorption refrigeration systems using Lithium bromide- water as the working fluid were the subject of a thorough exergy investigation. Parametric optimization is used to find the optimal temperatures for the main generator, intermediate generator, and condenser. Optimization of the solution distribution ratio is also performed with the ECOP and EDR in mind. For the same set of operational settings, we also compare the parallel flow cycle to the series flow arrangement.

**Gupta et al. (2020)** System using a parabolic trough collector (PTC) solar field and an ejector organic Rankine cycle (EORC) with integrated triple pressure level absorption (TPAS) is described. In addition to producing energy, this system also generates refrigeration output, although at a different temperature. The performance of the proposed system is investigated by thermodynamic analysis in terms of the impact of design parameters like solar beam radiation (SBR), turbine inlet pressure (TIP), turbine extraction pressure (TEP), and ejector evaporator temperature (EET) (EORTPAS). Energy efficiency of EORTPAS is shown to rise significantly upon incorporation of TPAS in EORC, whereas exergy efficiency is found to decrease.

**Sun et al. (2020)** examines R513a's energy and exergy performance as a drop-in replacement for R134a in an economized-cycle vapor-compression refrigeration system. In contrast to other studies, this one looks at the full working zone to determine whether or not R513a or R134a systems perform better in terms of capacity, COP, exergy destruction rate, and exergy efficiency.

**Mohammadi et al. (2020)** Using a carbon dioxide parallel compression economization-vapor compression refrigeration cycle with a 1000 kW capacity and evaporator temperatures of 35 °C to 45 °C, a variety of unique integrated cogeneration and trigeneration configurations were offered. This work's main contribution is the suggestion and thorough techno-economic evaluation of many realistic configurations of cogeneration and trigeneration.

**Abusaibaa et al. (2020)** This research examined the viability of implementing a solar absorption cycle in Najaf, Iraq. 105.6 kW of SEAC electricity are generated using evacuated tube collectors in the proposed setup (ETC). By simulating the system in TRNSYS (version 18), we can pick and optimise the various system parameters to boost the performance of the solar system, and in the process, we can create a realistic model of solar cooling that can be put to use in the efficient cooling of service buildings.

### **3. Objectives of Study**

1. To do a detail energetic analysis of tripple stage LiBr-H<sub>2</sub>O absorption system using First law of thermodynamics.
2. To develop a EES code using computer simulation program for simulating the cycle and do the validation of results with past studies.
3. To study the effect of exit temperature of generator, absorber, condenser and evaporator on COP, solution concentration and other parameters.

### **4. Research Methodology**

Evaporator, absorber, condenser, three generators, three heat exchangers, solution pump, expansion valves, and reduction valves are all part of the triple effect series absorption refrigeration system seen in Fig. 1. As indicated the vapour (refrigerant) is formed thrice. The first kind of production is a high-pressure generator that uses outside heat (HPG). The second and third generations are done via internal heat exchange at medium pressure generator (MPG) and low-pressure generator (LPG) accordingly.

“TEVAS is a four-pressure system. The three generators at high, medium and low pressure creates vapour three times than that of single effect absorption system. The system's high-pressure generator may be run on both waste heat and solar power.” Therefore, TEVAS has a COP that is three times higher than a system with a single absorption effect. Firstly, the first vapour formation is generated by heat input in HTG. The MTG and LTG skills of the second and third generations have been passed down and refined. TEVAS relies on a low-pressure system for its evaporator and absorber. The water evaporates as it absorbs heat from the thermic fluid. High pressure and the presence of LiBr raise the temperature at which water evaporates. In order to get the LiBr water mixture to the pressure condition of the second generator, gradual throttling is done, and steam at 180 C leaves the first chamber, causing the mixture to descend and enter the second chamber owing to change in pressure. In order to do this, a regenerator is used to transfer the heat to the same mixture at the conclusion of the cycle. The steam from the first chamber flows into the second chamber of the triple effect system which has the LiBr mixture from the first chamber, which is kept at 0.9 bar pressure and 120C. Water at 143 ° C and 4 bar is produced as a result of heat loss as steam from the first chamber condenses. When previously, the LiBr is lost as the mixture passes through the second regenerator, which is kept at 85 degrees Celsius at 0.1 bar pressure, and into the third chamber.

Through heat exchangers (SHE1, SHE2, and SHE3) located at states 1-5, the high-strength

solution from the absorber is pushed to the high-pressure generator temperature (HTG). Refrigerant vapour produced at state point 15 is piped to the MTG and LTG at states 16 and 17, where it combines with the refrigerated vapour produced at state point 18 and 19, before passing through the LTG at state point 18 and returning to the condenser at state point 19.

When the weak solution from the HTG escapes and transfers its heat to the strong solution in the SHE3, the strong solution heats up and is then slowed down before being sent to the medium pressure generator through solution throttle valve 2. (STV2). Subsequently, the MTG's weak solution is sent through SHE2, where the heat is conveyed to the strong solution, raising its temperature (STV3). LTG's weak solution travels via SHE1, where it transfers heat to the stronger solution, which then travels through solution throttle valve 1 and is absorbed (STV1). In the end, the diluted solution is returned to the absorber.

From states 22-23, expansion valve 1 restricts the flow of condenser-generated refrigerant vapour to the evaporator (RTV1). The evaporator is where the cooling process occurs. Consequently, after the cycle is begun, the solution flows in a series and is dispersed across three generators (HTG, MTG, and LTG), where it produces refrigerant vapour three times. Consequently, the process is now referred to as a "triple effect vapour absorption system" (TEVAS). The present work applies the first and second laws of thermodynamics to evaluate TEVAS's operational efficacy.

A higher COP can be achieved by the multi-effect absorption cycle if the heat source temperature is more than 150 °C. Since the crystallization issue becomes more pressing at higher temperatures, the circulation ratio and heat transfer area must be adjusted accordingly. It follows that the two low-temperature generators are to be used in the triple-effect cycle. Additionally, the solution's heat exchange capacity has been expanded.

Lithium bromide is the absorber and water is indeed the absorbent or refrigerant in this combination. For single effect machines to function, the heat source must be heated to temperatures higher than 80 degrees Celsius, and the performance coefficient (COP) is usually between 0.6 and 0.7. It has been shown that at 210°C, the COP of triple-effect systems may reach 1.7.

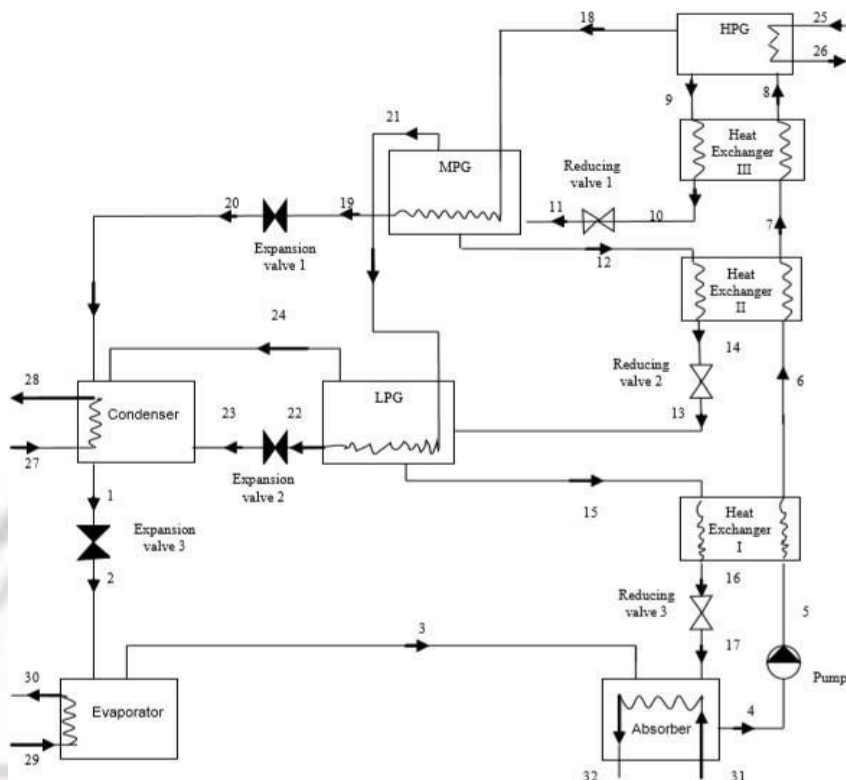

**Fig 1 Schematic diagram of Tripple effect vapour absorption system**

## 5. Result and Discussion

In this work, the energetics of the LiBr-H<sub>2</sub>O absorption system are analysed in great depth. We have analysed the situation using the first law of thermodynamics. In addition, a computer simulation software was created to code an EES, which can simulate the cycle and validate results with existing literature. The simulation model of the triple effect refrigeration system includes the equations for the mass, energy, and exergy balances, as well as the many supplementary linkages. A computer programme built in EES was created to answer the massive set of equations all at once. Computer simulation was carried out in order to estimate the various stream parameters and the quantity of heat and work exchanged by all equipments of the chiller. The tables 1 show the findings of the energetic and exergetic analysis of the process so when HPG temperature is set to ( $T_{gh}=180^{\circ}\text{C}$ ), the condenser temperature is set to  $30^{\circ}\text{C}$ , and the evaporator temperature is set to  $5^{\circ}\text{C}$ . The COP of the triple impact cycle has been calculated for a certain set of operational parameters that may be useful in practise.

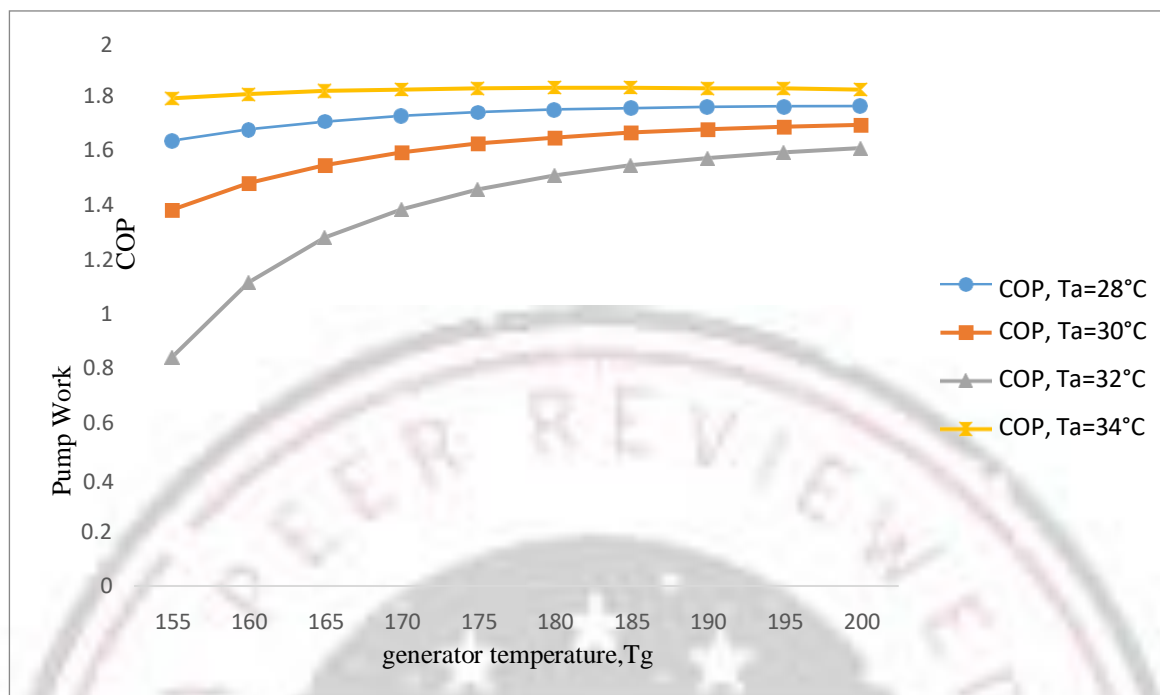

**Fig 2 Effect of generator exit temperature on component's COP at different absorber temperature**

## 6. Conclusion

This research involves the creation of an analysis approach and its subsequent application to a computer code in order to mimic the performance of a triple effect absorption refrigeration system in a variety of environments. We do a first law study of the absorption of lithium bromide, water vapour, and lithium ions. EES code was used to create a software programme that verifies the COP and heat transfer in the generator, absorber, condenser, and evaporator. Thermodynamic equilibrium equations including mass, energy, entropy, exergy, and the energy and exergy efficiency equations are used to examine the COP, circulation ratio, and heat load of the entire system.

## References

1. Agarwal, Shyam, Akhilesh Arora, and B. B. Arora. "Energy and exergy analysis of vapor compression–triple effect absorption cascade refrigeration system." *Engineering Science and Technology, an International Journal* 23, no. 3 (2020): 625-641.
2. Chen, Wei, Chenbin Xu, Haibo Wu, Yang Bai, Zoulu Li, and Bin Zhang. "Energy and exergy analyses of a novel hybrid system consisting of a phosphoric acid fuel cell and a triple- effect compression–absorption refrigerator with [mmim] DMP/CH<sub>3</sub>OH as working fluid." *Energy* 195 (2020): 116951.



3. Dubey, Alok Manas. "Modified vapour absorption refrigeration cycles." *International Journal of Ambient Energy* (2020): 1-7.
4. Waseem, Sheharyar, Tahir Abdul Hussain Ratlamwala, Yawar Salman, and Abdallah Ayub Bham. "Geothermal and solar based mutli-generational system: A comparative analysis." *International Journal of Hydrogen Energy* 45, no. 9 (2020): 5636-5652.
5. Azhar, Md, and M. Altamush Siddiqui. "Comprehensive exergy analysis and optimization of operating parameters for double effect parallel flow absorption refrigeration Cycle." *Thermal Science and Engineering Progress* 16 (2020): 100464.
6. Gupta, Devendra Kumar, Rajesh Kumar, and Naveen Kumar. "Performance analysis of PTC field based ejector organic Rankine cycle integrated with a triple pressure level vapor absorption system (EORTPAS)." *Engineering Science and Technology, an International Journal* 23, no. 1 (2020): 82-91.
7. Sun, Jian, Wenhua Li, and Borui Cui. "Energy and exergy analyses of R513a as a R134a drop-in replacement in a vapor compression refrigeration system." *International Journal of Refrigeration* 112 (2020): 348-356.
8. Mohammadi, Kasra, and Kody Powell. "Thermodynamic and economic analysis of different cogeneration and trigeneration systems based on carbon dioxide vapor compression refrigeration systems." *Applied Thermal Engineering* 164 (2020): 114503.
9. Abusaibaa, Ghaith Yahay, Anwer Basim Al-Aasam, Ali HA Al-Waeli, Ali Wadi Abbas Al-Fatlawi, and Kamaruzzaman Sopian. "Performance Analysis of Solar Absorption Cooling Systems in Iraq." *International Journal of Renewable Energy Research (IJRER)* 10, no. 1 (2020): 223-230.
10. Azhar, Md, and M. Altamush Siddiqui. "Exergy analysis of single to triple effect lithium bromide-water vapour absorption cycles and optimization of the operating parameters." *Energy conversion and management* 180 (2019): 1225-1246.
11. Toghyani, Somayyeh, Ebrahim Afshari, E. Baniasadi, and M. S. Shadloo. "Energy and exergy analyses of a nanofluid based solar cooling and hydrogen production combined system." *Renewable energy* 141 (2019): 1013-1025.
12. Mishra, R. S. "Thermal performance of cascaded vapour compression absorption systems." *International Journal of Research in Engineering and Innovation (IJREI), ISSN (Online)* (2019): 2456-6934.
13. Azhar, Md, and M. Altamush Siddiqui. "First and Second Law Analyses of Double Effect Parallel and Series Flow Direct Fired Absorption Cycles for Optimum Operating

- Parameters." *Journal of Energy Resources Technology* 141, no. 12 (2019).
14. Bagheri, B. Safarnezhad, R. Shirmohammadi, S. M. S. Mahmoudi, and M. A. Rosen. "Optimization and comprehensive exergy-based analyses of a parallel flow double-effect water-lithium bromide absorption refrigeration system." *Applied Thermal Engineering* 152 (2019): 643-653.
  15. Singh, Gaurav, and Ranjan Das. "Energy saving potential of a combined solar and natural gas-assisted vapor absorption building cooling system." *Journal of Solar Energy Engineering* 141, no. 1 (2019).
  16. Mishra, R. S. "Thermal performances (first law efficiency, exergy destruction ratio & exergetic efficiency) of cascade single effect ammonia-water (NH<sub>3</sub>-H<sub>2</sub>O) vapour absorption refrigeration system coupled with vapour compression refrigeration using ecofriendly refrigerants in the low temperature cycle of VCRS system." *International Journal of Research in Engineering and Innovation* 3 (2019): 1-5.
  17. Arshad, Muhammad Umer, Muhammad Usman Ghani, Atta Ullah, Afşin Güngör, and Muhammad Zaman. "Thermodynamic analysis and optimization of double effect absorption refrigeration system using genetic algorithm." *Energy Conversion and Management* 192 (2019): 292-307.
  18. Chahartaghi, Mahmood, Hesam Golmohammadi, and Arsalan Faghih Shojaei. "Performance analysis and optimization of new double effect lithium bromide–water absorption chiller with series and parallel flows." *International journal of refrigeration* 97 (2019): 73-87.
  19. Alazazmeh, Ayman J., Esmail Mokheimer, Abdul Khaliq, and Bilal A. Qureshi. "Performance analysis of a solar-powered multi-effect refrigeration system." *Journal of Energy Resources Technology* 141, no. 7 (2019).